



**HB6000, HB6000/220, and  
HB6024  
Heater/Blower Kits**

**Installation/Operation  
Manual C496M (12/90)**

### **1.0 WARNINGS**

Prior to installation and use of this product, the following WARNINGS should be observed.

1. Installation and servicing should only be done by Qualified Service Personnel and conform to all Local codes.
2. Installation should be in accordance with all applicable local and national electric codes, utilizing approve materials only.
3. Only use replacement parts recommended by Pelco.

Please thoroughly familiarize yourself with the information in this manual prior to installation and operation.

### **2.0 SCOPE**

The information within this manual covers the installation of the HB6000, HB6000/220, and HB6024 Heater/Blower Kits.

### **3.0 DESCRIPTION**

The HB6000 (120 VAC), HB6000/220 (230 VAC), and the HB6024 (24 VAC) are field installed heater/blower kits for the HS1000 and HS6000 series high security enclosures. These heater/blower kits will help stabilize the internal enclosure temperatures when the enclosures are subjected to more extreme conditions.

The heaters provide 80 watts of heat thermostatically controlled to turn ON at 40°F (4.44°C) and OFF at 60°F (15.56°C).

### 3.1 MODELS

HB6000	120 VAC thermostatically controlled heater and blower. Heater provides 80 watts of heat and activates ON at 40°F (4.44°C) and OFF at 60°F (15.56°C). Blower provides internal air circulation (12 cfm at 4 watts) and activates ON at 110°F (43.33°C) and OFF at 80°F (26.67°C).
HB6000/220	Same as HB6000 except 230 VAC operation. (Blower: 12 cfm at 4.5 watts)
HB6024	Same as HB6000 except 24 VAC operation. (Blower: 19 cfm at 3 watts)

### 3.2 INPUT POWER REQUIREMENTS

Blower:	HB6000	—	0.04 amp (4.5 vA)
	HB6000/220	—	0.04 amp (4.5 vA)
	HB6024	—	0.18 amp (4.5 vA)
Heater:	HB6000	—	0.68 amp (80 vA)
	HB6000/220	—	0.68 amp (80 vA)
	HB6024	—	3.30 amp (80 vA)

### 3.3 RECOMMENDED CABLE SIZE

**CAUTION:** When using a single power source for both the camera and accessories, the camera power consumption must be taken into consideration when determining the wire gauge.

The following cable sizes are the minimum recommended for use with the combination of blower/heater/camera.

Model	Input Voltage	Power Consumption	Cable Size	Cable Distance
<b>HB6000</b>	120 VAC	90 watts	22 Awg	464.7 ft (141.64 m)
			20 Awg	738.9 ft (225.22 m)
			18 Awg	1,175.5 ft (358.29 m)
			16 Awg	1,865.7 ft (568.66 m)
<b>HB6000/220</b>	230 VAC	90 watts	24 Awg	1,047.4 ft (319.25 m)
			22 Awg	1,666.0 ft (507.80 m)
			20 Awg	2,649.2 ft (807.48 m)
			18 Awg	4,214.6 ft (1,284.61 m)
			16 Awg	6,688.8 ft (2,038.75 m)
<b>HB6024</b>	24 VAC	90 watts	20 Awg	31.5 ft (9.60 m)
			18 Awg	50.2 ft (15.30 m)
			16 Awg	79.6 ft (24.26 m)
			14 Awg	127.0 ft (38.71 m)

### 3.4 POWER REQUIREMENTS

The blower and heater require a 24 VAC/120 VAC/230 VAC, 50/60 Hz single phase power source. They use the following wattage when in operation.

Blower:	4.5 watts
Heater:	80 watts

### 4.0 INSTALLATION

To install the HB6000, HB6000/220, and HB6024 perform the following steps. Refer to Figure 1.

#### 4.1 HEATER ASSEMBLY

1. Open the cover or access door.
2. The heater brackets are designed to attach to two (2) adjacent studs retaining the window.
3. Remove any two (2) adjacent nuts and washers (preferably at the bottom of the window) on both sides of the window.
4. Place the heater brackets on the studs, heaters angled away from the window, and replace and tighten the hardware.

#### 4.2 BLOWER/PCB ASSEMBLY

1. Open the cover or access door(s).
2. On the HS1000, the blower/PCB bracket is designed to attach to any two (2) adjacent studs retaining the bottom plate. On the HS6000, the blower/PCB bracket is designed to attach to the two (2) studs at the bottom of the window.
3. On the HS1000, remove any two (2) adjacent nuts and washers retaining the bottom plate to the mounting frame. On the HS6000, remove the nuts and washers retaining the bottom of the window.
4. Place the blower/PCB bracket over the studs and replace and tighten the hardware

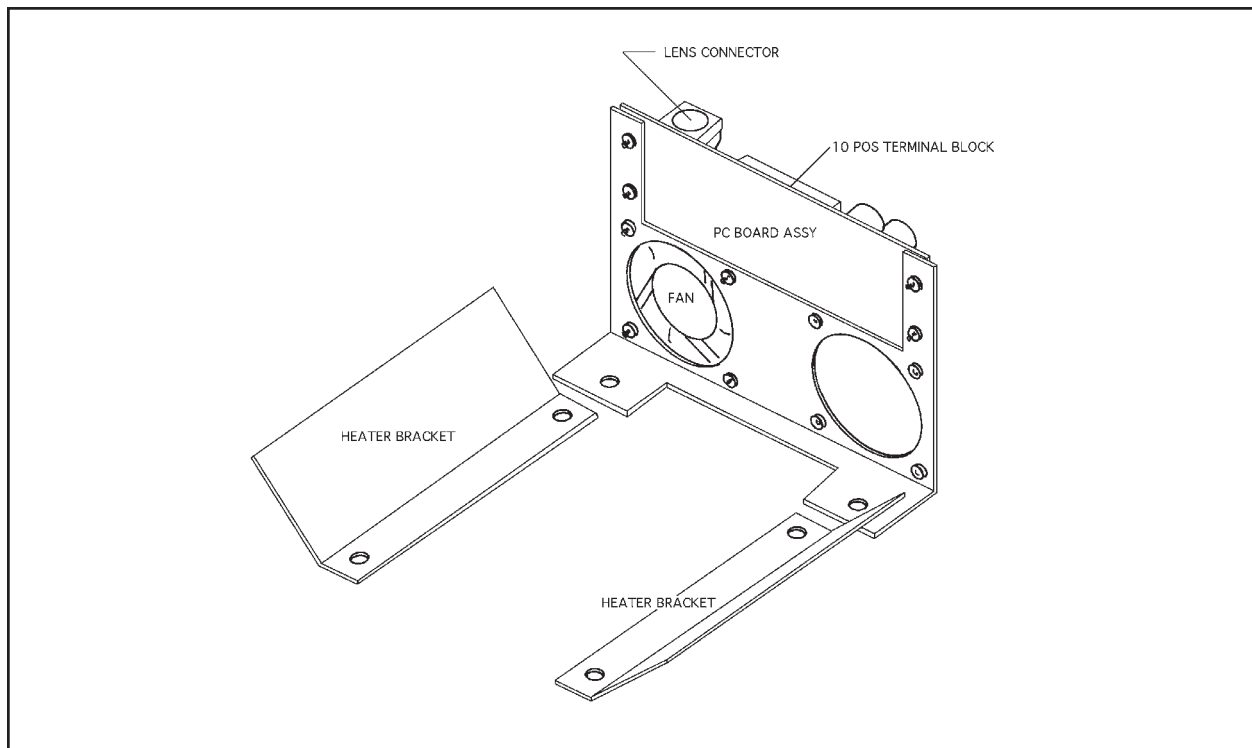

Figure 1. HB6000, HB6000/220, and HB6024 Assembly

### 4.3 HEATER/BLOWER WIRING

The blower is factory wired to the PCB assembly.

Connect the heaters to the PCB assembly as shown in the respective wiring diagrams (refer to Figure 2, Figure 3, or Figure 4).

Supply AC line voltage (230 VAC, 120 VAC, or 24 VAC) as shown.

### 4.4 ELECTRICAL CONNECTION

After the cable has been routed, all wire connections should be made (i.e., video, lens, camera power, heaters). A 6-position terminal block has been provided to assist in this.

**CAUTION:** When using a single power source for both the camera and accessories, the camera power consumption must be taken into consideration when determining the wire gauge. Also, make certain that all electrical connections are done properly and meet electrical codes.

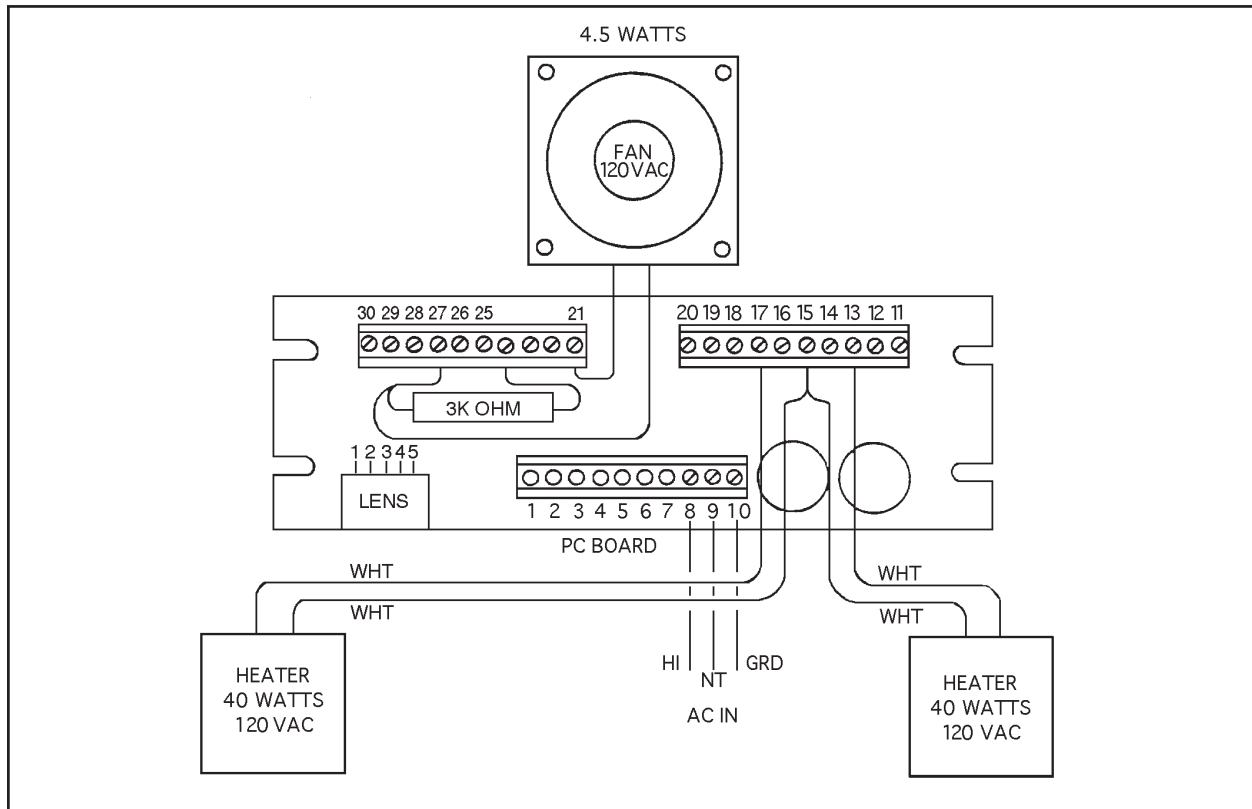

**Figure 2.** HB6000/220 Heater/Blower Kit Wiring Diagram (230 VAC)

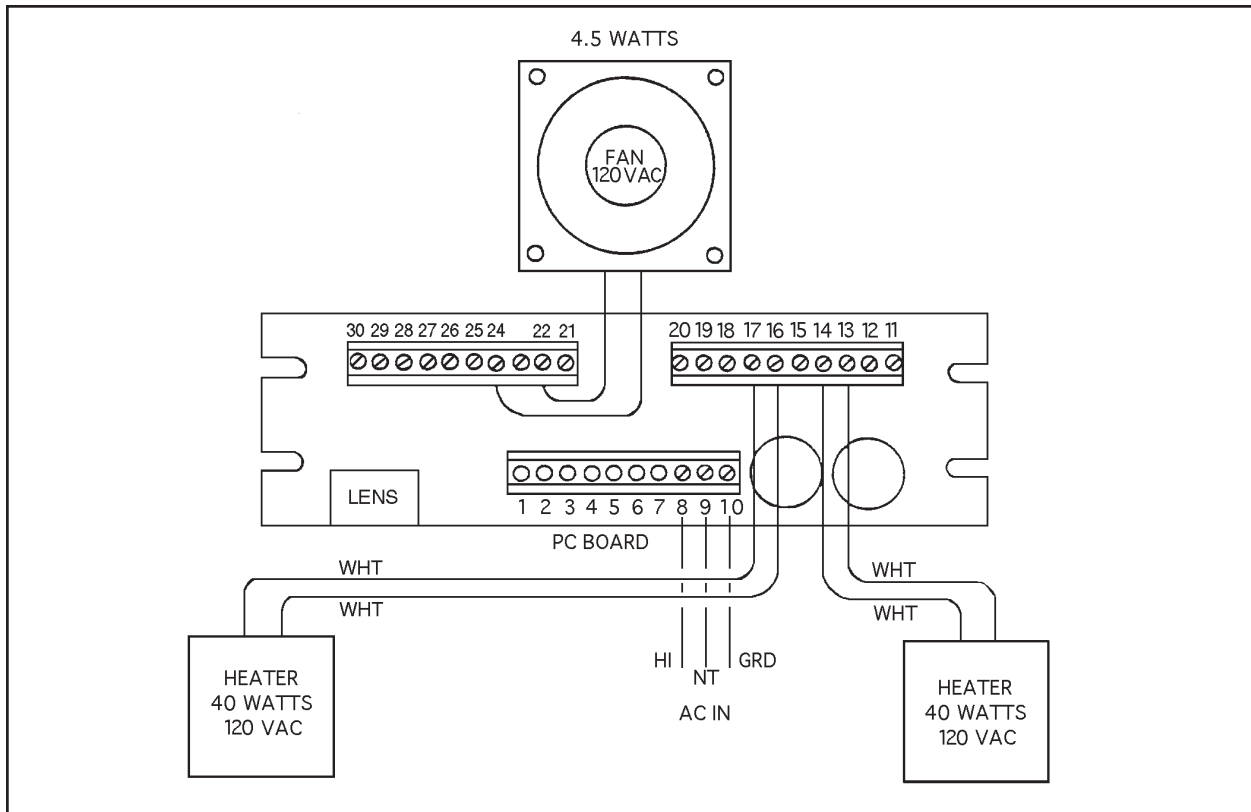

**Figure 3.** HB6000 Heater/Blower Kit Wiring Diagram (120VAC)

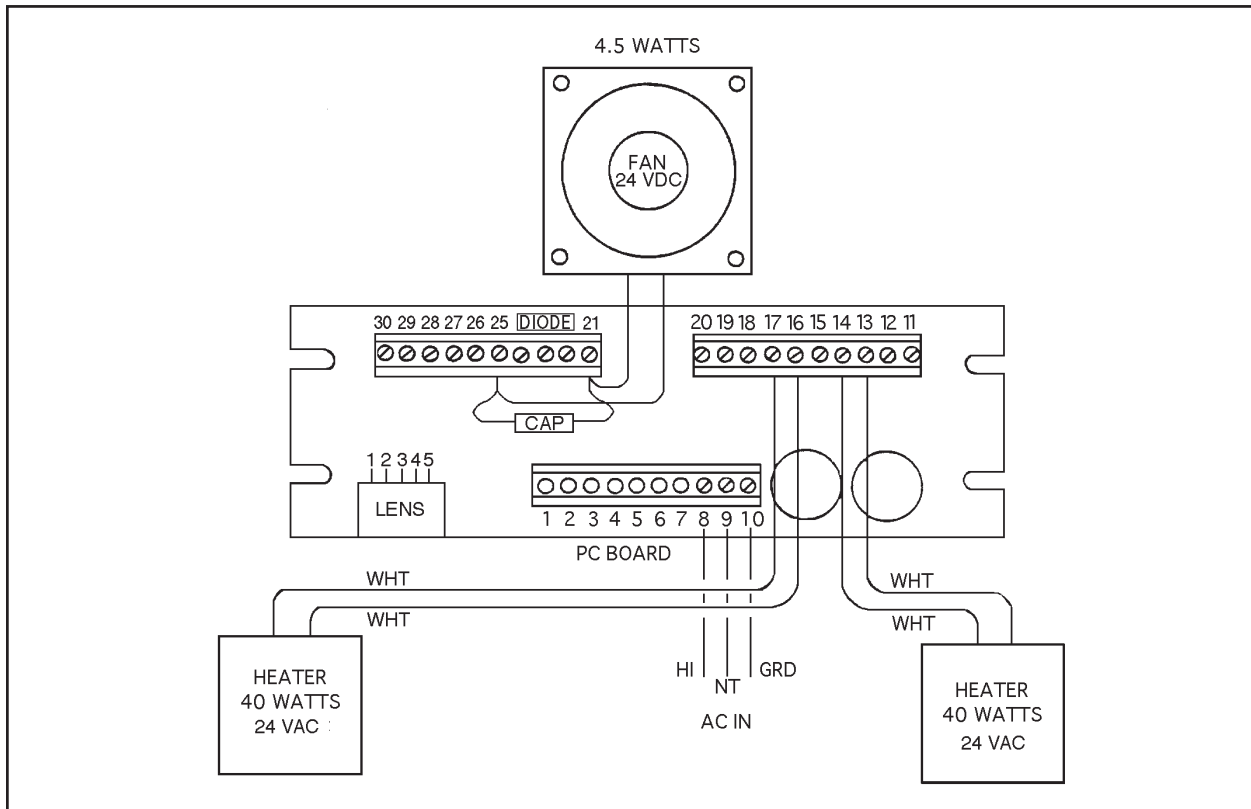

**Figure 4.** HB6024 Heater/Blower Kit Wiring Diagram (24 VAC)

**5.0 MECHANICAL PARTS LIST FOR HB6000/220 (230 VAC) HEATER/BLOWER KIT**

Item No.	Qty	Description	Part Number
1	1	Bracket, Fan/PCB, HB6000	HB60004000COMP
2	1	PCB Assembly, Term/Thermo, EH4500 Series	PCB9000256ASSY
3	1	Fan 10CFM 2.36" SQ 115 VAC	MM750010003
4	2	Bracket, Heater, HB6000	HB60004001COMP
5	1	Insulator, PCB, EH4500, 6.25" x 2.00"	EH450010256
6	2	Heater Blanket 2" x 2" 115V40W	EHWD10087
7	1	Resistor 3K Ohm, 10W	RES003.0K10.00

**MECHANICAL PARTS LIST FOR HB6000 (120 VAC) HEATER/BLOWER KIT**

Item No.	Qty	Description	Part Number
1	1	Bracket, Fan/PCB, HB6000	HB60004000COMP
2	1	PCB Assembly, Term/Thermo, EH4500 Series	PCB9000256ASSY
3	1	Fan 10CFM 2.36" SQ 115VAC	MM750010003
4	2	Bracket, Heater, HB6000	HB60004001COMP
5	1	Insulator, PCB, EH4500, 6.25" x 2.00"	EH450010256
6	2	Heater Blanket 2" x 2" 115V40W W/PSA	EHWD10087

**MECHANICAL PARTS LIST FOR HB6024 (24 VAC) HEATER/BLOWER KIT**

Item No.	Qty	Description	Part Number
1	1	Diode Bridge Rectifier 1A400PRV MOT	DIOMDA104
2	1	PCB Assy, Term/Thermo, EH4500 Series	PCB9000256ASSY
3	1	FAN 11CFM 2.36" SQ. 24VDC, D24-B10TRW	ED210005
4	2	Bracket, Heater, HB6000	HB60004001COMP
5	1	Insulator, PCB, EH4500, 6.25" x 2.00"	EH450010256
6	2	Heater Blanket 2" x 2" 24V40W W/PSA	EHHK10087
7	1	Diode Bridge Rectifier 1A400PRV MOT	DIOMDA104

## **6.0 SPECIFICATIONS**

### **ELECTRICAL**

Input Voltage: 24 VAC/120 VAC/230 VAC, 50/60Hz

Electrical

Connection: One 10-position terminal block (input)  
One 6-pin lens connector  
Two (2) 10-position terminal blocks for internal wiring

## 7.0 WARRANTY AND RETURN INFORMATION

### WARRANTY

Pelco will repair or replace, without charge, any merchandise proved defective in material or workmanship for a period of one year after the date of shipment.

Exceptions to this warranty are as noted below:

- Five years on FT/FR8000 Series fiber optic products.
- Three years on Genex® Series products (multiplexers, server, and keyboard).
- Three years on Camclosure® and fixed camera models, except the CC3701H-2, CC3701H-2X, CC3751H-2, CC3651H-2X, MC3651H-2, and MC3651H-2X camera models, which have a five-year warranty.
- Two years on standard motorized or fixed focal length lenses.
- Two years on Legacy®, CM6700/CM6800/CM9700 Series matrix, and DF5/DF8 Series fixed dome products.
- Two years on Spectra®, Esprit®, ExSite™, and PS20 scanners, including when used in continuous motion applications.
- Two years on Esprit® and WW5700 Series window wiper (excluding wiper blades).
- Eighteen months on DX Series digital video recorders, NVR300 Series network video recorders, and Endura™ Series distributed network-based video products.
- One year (except video heads) on video cassette recorders (VCRs). Video heads will be covered for a period of six months.
- Six months on all pan and tilts, scanners or preset lenses used in continuous motion applications (that is, preset scan, tour and auto scan modes).

Pelco will warrant all replacement parts and repairs for 90 days from the date of Pelco shipment. All goods requiring warranty repair shall be sent freight prepaid to Pelco, Clovis, California. Repairs made necessary by reason of misuse, alteration, normal wear, or accident are not covered under this warranty.

Pelco assumes no risk and shall be subject to no liability for damages or loss resulting from the specific use or application made of the Products. Pelco's liability for any claim, whether based on breach of contract, negligence, infringement of any rights of any party or product liability, relating to the Products shall not exceed the price paid by the Dealer to Pelco for such Products. In no event will Pelco be liable for any special, incidental or consequential damages (including loss of use, loss of profit and claims of third parties) however caused, whether by the negligence of Pelco or otherwise.

The above warranty provides the Dealer with specific legal rights. The Dealer may also have additional rights, which are subject to variation from state to state.

If a warranty repair is required, the Dealer must contact Pelco at (800) 289-9100 or (559) 292-1981 to obtain a Repair Authorization number (RA), and provide the following information:

1. Model and serial number
2. Date of shipment, P.O. number, Sales Order number, or Pelco invoice number
3. Details of the defect or problem If there is a dispute regarding the warranty of a product which does not fall under the warranty conditions stated above, please include a written explanation with the product when returned.

Method of return shipment shall be the same or equal to the method by which the item was received by Pelco.



This equipment contains electrical or electronic components that must be recycled properly to comply with Directive 2002/96/EC of the European Union regarding the disposal of waste electrical and electronic equipment (WEEE). Contact your local dealer for procedures for recycling this equipment.

### RETURNS

In order to expedite parts returned to the factory for repair or credit, please call the factory at (800) 289-9100 or (559) 292-1981 to obtain an authorization number (CA number if returned for credit, and RA number if returned for repair).

All merchandise returned for credit may be subject to a 20% restocking and refurbishing charge.

Goods returned for repair or credit should be clearly identified with the assigned CA or RA number and freight should be prepaid. Ship to the appropriate address below.

If you are located within the continental U.S., Alaska, Hawaii or Puerto Rico, send goods to:

Service Department  
Pelco  
3500 Pelco Way  
Clovis, CA 93612-5699

If you are located outside the continental U.S., Alaska, Hawaii or Puerto Rico and are instructed to return goods to the USA, you may do one of the following:

If the goods are to be sent by a COURIER SERVICE, send the goods to:

Pelco  
3500 Pelco Way  
Clovis, CA 93612-5699 USA

If the goods are to be sent by a FREIGHT FORWARDER, send the goods to:

Pelco c/o Expeditors  
473 Eccles Avenue  
South San Francisco, CA 94080 USA  
Phone: 650-737-1700  
Fax: 650-737-0933